

# GHOSTS & GHOULS

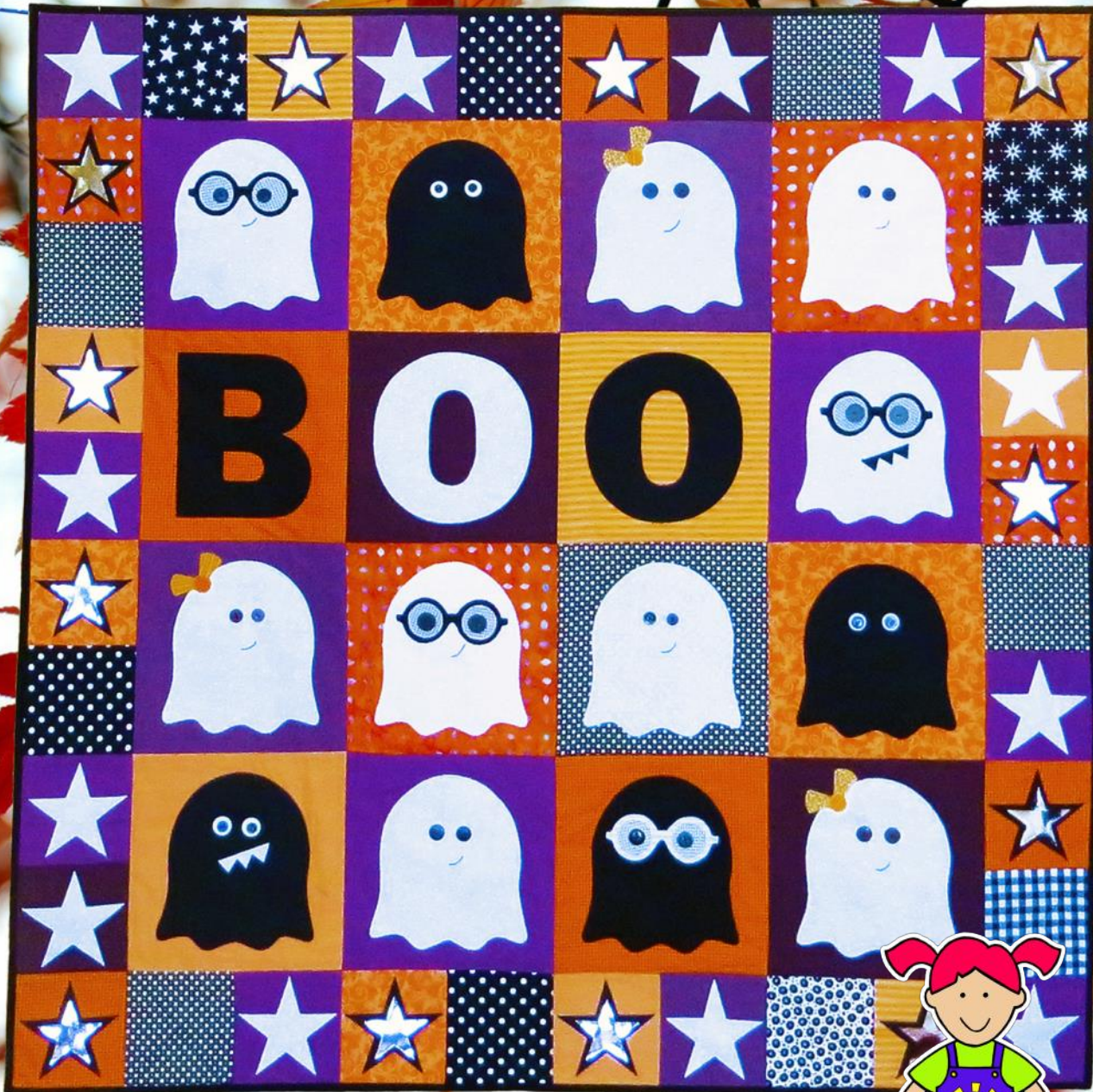

This is a free pattern provided by  
© The Red Boot Quilt Company 2017  
STRICTLY NOT FOR RESALE OR DISTRIBUTION



## The Red Boot Quilt Company

# GHOSTS & GHOULS

Wall-hanging 40 1/2in square ♦ Trick or Treat Bag 12in square ♦ Bunting 8in square flags/adjustable length

## BEFORE THE FUN BEGINS

- ♦ Please read all instructions before you begin.
- ♦ Abbreviations. "WOF" = 'width of the fabric'.
- ♦ Are you new to patchwork & quilting? There are many fantastic classes being run at your local patchwork and quilting store. You can also find fantastic step-by-step tutorials on the internet that will help you get started. This pattern is not intended to replace a class.
- ♦ **Requirements are based on fabric 115cm (44in) wide unless otherwise stated. Fabric requirements may differ from person to person due to cutting methods. If in doubt it is a good idea to purchase a little extra fabric.**
- ♦ Fusible webbing requirements will vary greatly between products and projects. Assume you will need a lot and go from there!
- ♦ 1/4in seam allowances are used throughout unless otherwise stated.
- ♦ Pre-washed 100% cotton fabrics are recommended.
- ♦ Press all seams towards the darker fabric or in the direction that creates the least bulk.
- ♦ Please refer to the photo of the project and the quilt diagrams to help with colour choices and layout.
- ♦ **I would recommend using an applique mat with all but the most simple applique shapes.**
- ♦ Our patterns are proof-read and made by our lovely testers but sometimes mistakes do slip by us. Please let us know if you come across an error so we can correct it.
- ♦ **Buttons and beads are NOT suitable for children under three (3) years of age due to them being a choking hazard. Please replace buttons and beads with applique or embroidery.**

### HOW TO PRINT TEMPLATES FROM PDF PATTERN

- ♦ All of the templates are provided at their full size. Make sure that your printer is set to print at 100% with no scaling or cropping.
- ♦ Some templates are divided into two, or sometimes more, sections and will need to be joined to make the complete template. Simply match the shapes along the dotted lines, then use adhesive tape to stick them together.
- ♦ If you have any difficulties please contact me at my email address [redbootquilts@bigpond.com](mailto:redbootquilts@bigpond.com) and I will help you the best I can.

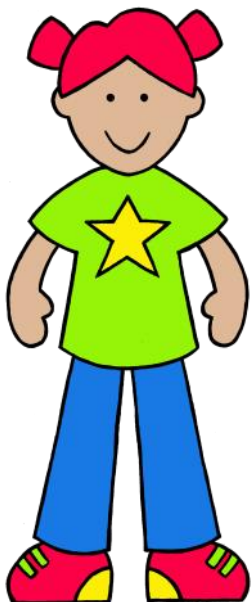

*This design and its instructions, diagrams and templates are protected by copyright. They may not be reproduced by any process. If the project is being made by a group of crafters, each person is required to have purchased their own copy of the pattern. The instructions and information contained in this pattern is given in good faith, but no guarantee is given due to the fact we have no control over the techniques and materials used.*

© The Red Boot Quilt Company 2017.

© Antonie Alexander, The Red Boot Quilt Company 2017  
Website: [www.theredbootquiltcompany.com](http://www.theredbootquiltcompany.com) ★ Email: [redbootquilts@bigpond.com](mailto:redbootquilts@bigpond.com)  
Phone: (61) 7 3325 0172

# \* therm.o.web adhesives, interfacings and more...



**The Red Boot Quilt Company**

# \* therm·o·web

adhesives, interfacing and more...

## Adding Deco|Foil™ to your Projects

- ◆ Always follow the manufacturer's instructions and fuse one or two practice shapes to scrap fabric first.

1. Use a sharp pencil to trace the Deco|Foil™ shapes from the template pages onto the paper side of the Hot Melt Adhesive paper. Leave approx. 1/4in between each shape. When you have finished tracing, cut out the individual shapes **on** the lines. If you find it difficult to see the shape through the paper adhesive, use a lightbox or sunny window to see the template more clearly.

*Remember you don't need to reverse your Deco|Foil™ shapes!*

2. Preheat your iron to a medium heat, and turn off the steam setting.

Place the cut out shape on the project with the adhesive (rough side) facing downwards. Place the parchment paper (included with the adhesive) on top of the shape, then press for **30 seconds** only. Repeat the process, if necessary, until the whole shape is bonded.

Remove the parchment paper and let the adhesive cool thoroughly before removing the backing paper.

3. Cut a piece of foil slightly larger than the adhesive shape. Place the foil with the colour side facing up, on top of the adhesive shape, making sure the shape is completely covered.

Place the parchment paper on top of the foil, then iron slowly for **30-40 seconds** using firm pressure.

Remove the parchment paper and let the foil cool thoroughly. Peel the foil sheet away from the adhesive to reveal the finished shape.

4. Repeat to add as much Deco|Foil™ to the project as you require .

Remember that once you have added the foil to your project it cannot be ironed again. Be very careful not to touch the foil previously adhered to the project, with the iron when you are working.

[You can find the stockists for all Thermoweb products here.](#)  
[You can buy The Red Boot Quilt Company patterns here.](#)



# The Red Boot Quilt Company

# GHOSTS & GHOULS

## What You Will Need for the Wall-hanging

- ◆ 45cm (1/2 yard) total each of assorted solid purple and orange-on-orange print fabrics for the background blocks
- ◆ 25cm (1/4 yard) total of assorted black & white print fabrics for the background blocks
- ◆ 55cm (5/8 yard) of white-on-white print fabric for the applique
- ◆ 80cm (7/8 yard) of solid black fabric for the applique and binding
- ◆ Scraps of grey small check fabric and yellow print fabrics for the applique
- ◆ (13) pairs of small to medium black buttons for eyes
- ◆ Lightweight fusible webbing—I use and recommend HeatnBond Lite for all my projects
- ◆ Stranded embroidery thread for the facial features
- ◆ Matching thread to suit your favourite applique stitching method
- ◆ A piece of wadding (batting) measuring at least 46 1/2in square
- ◆ A piece of fabric, pieced or whole, measuring at least 46 1/2in square for the backing
- ◆ 25cm (1/4 yard) of coordinating fabric for the hanging sleeve
- ◆ General sewing supplies
- ◆ 1 packet of Deco|Foil™ Hot Melt Adhesive and 1 tube of silver foil (*optional*)

### **TIP**

*Supplement the fabrics in the requirements list with fabrics from your stash to add visual interest to your project.*

## Cutting Instructions for the Wall-hanging

1. **From the assorted orange-on-orange print fabrics, cut a total of:**
  - ◆ (8) 8 1/2in squares for the background blocks.
  - ◆ (13) 4 1/2in squares for the border.
2. **From the assorted solid purple fabrics, cut a total of:**
  - ◆ (7) 8 1/2in squares for the background blocks.
  - ◆ (12) 4 1/2in squares for the border.
3. **From the assorted black & white print fabrics, cut a total of:**
  - ◆ (1) 8 1/2in square for the background blocks.
  - ◆ (11) 4 1/2in squares for the border.
4. **From the solid black fabric, cut:**
  - ◆ (5) strips, 2 1/2in x WOF for the binding.
5. **Cut (1) 8in x 40 1/2in strip of fabric for the hanging sleeve.**

## How to Make the Wall-hanging

1. Trace the applique shapes from the template pages onto the paper side of the fusible webbing using a sharp pencil; leave approx. 1/2in between each shape. When you have finished tracing, roughly cut out the individual shapes 1/4in outside the traced lines.

*You will need to trace (13) ghost shapes, (4) pairs of glasses, (3) bows, (2) grumpy mouths, (25) stars, and the letters needed to spell the word 'BOO'.*

### **Diagram 1** ▶

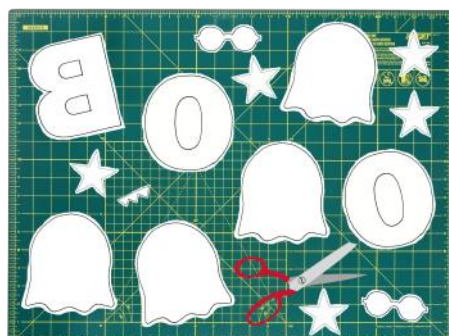
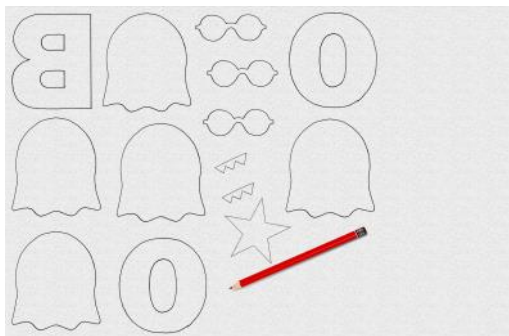

- Fuse the applique shapes to the wrong side of the fabrics you have chosen for the project following the manufacturer's instructions. Cut the shapes out carefully on the lines when cool to the touch. Remove the backing paper from the applique shapes as you go.
- Use the template and the colour photograph as a guide to centre and fuse the applique ghosts and letters to the assorted 8 1/2in background blocks, and the stars to the assorted 4 1/2in border blocks.

Stitch around the applique shapes using your favourite method. I stitched around my shapes using machine blanket stitch and matching thread. Use a light, sharp pencil to draw the features on the ghosts, then backstitch using two strands of contrasting embroidery thread. Set the star blocks aside.

- The wall-hanging is made up of (4) rows, each with (4) blocks. Use the photograph and Diagram 2 as a guide to lay out all of the 8 1/2in blocks on a flat surface. When you are happy with the placement of the blocks, sew them together in horizontal rows. Press the seams in each row in opposite directions.

Pin and then sew the rows together, carefully matching the seams, to make the centre of the wall-hanging. Press well.

**Diagram 2** ▶

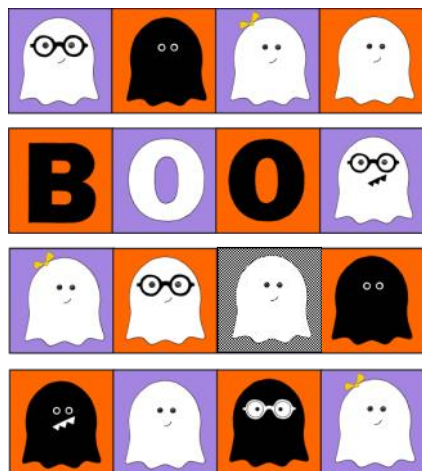

*The eyes are shown for illustration purposes only.*

- Use the colour photograph and Diagram 3 as a guide to sew (8) assorted 4 1/2in squares together to make a border strip. Repeat to make (2). Press the seams in the direction that will allow them to butt together with the centre of the wall-hanging.

Pin and then sew them to the top and bottom of the wall-hanging, carefully matching the seams. Press the seams toward the borders.

- Repeat to sew (10) assorted 4 1/2in squares together to make a border strip. Make (2).

Pin and then sew them to the left and right-hand sides of the wall-hanging, carefully matching the seams. Press the seams toward the borders. Press well.

**Diagram 3** ▶

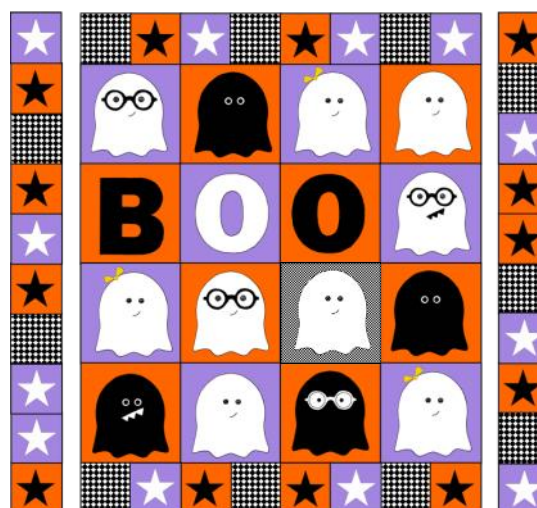

7. Trim the backing fabric, if necessary, to make a piece measuring approx. 46 1/2in square.
8. Layer the backing, wadding (batting) and wall-hanging, then baste them together using your favourite method. Start quilting from the centre and work your way out to the edges.

When you have finished quilting, cut away the excess wadding and backing fabric, and square all four edges of the wall-hanging.

9. Sew buttons to the ghosts' faces for eyes where indicated on the pattern template. Sew the buttons in place through all thicknesses of the wall-hanging using strong thread. Knot securely. To make googly eyes like mine, sew (2) contrasting buttons on top of each other—the bottom button needs to be larger than the top button. Set aside.
10. Turn over a narrow 1/4in hem on both short ends of the 8in x 40 1/2in strip of fabric you have chosen for the hanging sleeve. Press.

Turn over a second hem, this time 1/2in wide. Press, then topstitch it in place using matching thread. Fold the hanging sleeve in half lengthwise with wrong sides facing. Press gently.

11. Centre the folded hanging sleeve along the back, top raw edge of the wall-hanging, leaving approx. 1in of clear space at either end. Pin and then baste it in place. Set aside.

#### **Diagram 4 ▼**

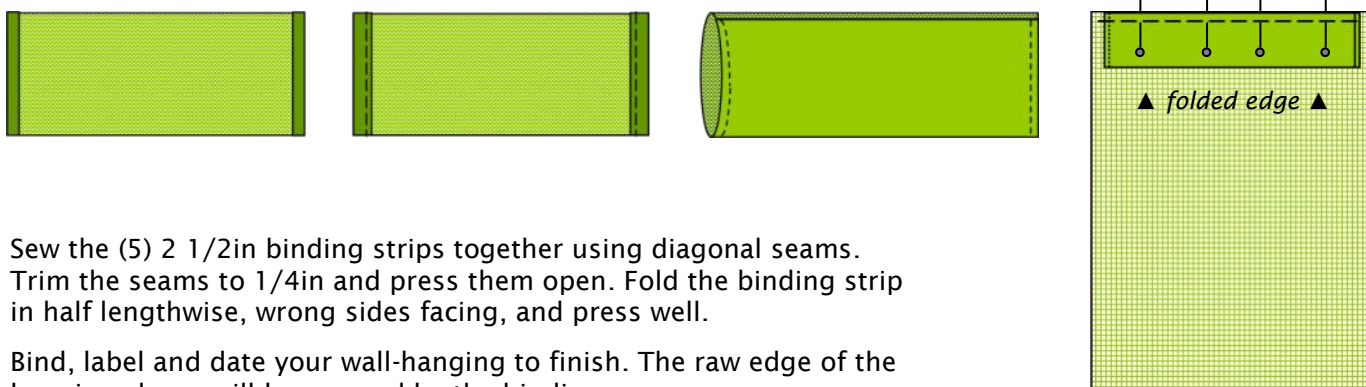

12. Sew the (5) 2 1/2in binding strips together using diagonal seams. Trim the seams to 1/4in and press them open. Fold the binding strip in half lengthwise, wrong sides facing, and press well.

Bind, label and date your wall-hanging to finish. The raw edge of the hanging sleeve will be covered by the binding.

13. Finish the hanging sleeve by hand sewing the bottom edge of the sleeve to the back of the wall-hanging. When sewing the bottom edge of the hanging sleeve to the project, allow a little slack (make it puffy) so the hanging rod will fit and not bulge or show on the front.
14. I've used silver Deco|Foil™ to add sparkle and bling to the black stars around the border of the wall-hanging. Always follow the manufacturer's instructions, and make a test piece first.

Add as much Deco|Foil™ as you want sparkle!

***I like to use buttons on my projects but they aren't suitable for children under three (3) years of age due to them being a choking hazard.***

***Replace the buttons with appliqué or embroidery when you are making the projects.***

# GHOSTS & GHOULS

## What You Will Need for the Trick or Treat Bag

- ◆ Scraps of solid purple, orange-on-orange print, and black & white print fabrics
- ◆ 35cm (3/8 yard) of solid black fabric
- ◆ 35cm (3/8 yard) of coordinating fabric for the lining
- ◆ A scrap of white fabric for the applique
- ◆ (1) 2in x 42in strip of lightweight interfacing for the bag straps
- ◆ (1) pair of small to medium black buttons for eyes
- ◆ Lightweight fusible webbing
- ◆ Stranded embroidery thread for the facial features
- ◆ Matching thread to suit your favourite applique stitching method
- ◆ General sewing supplies
- ◆ Deco|Foil™ Hot Melt Adhesive and silver foil (*optional*)



## Cutting Instructions for the Trick or Treat Bag

1. **From the assorted orange, purple, and black & white print fabrics, cut a total of:**
  - ◆ (24) 2 1/2in squares
2. **From the solid black fabric, cut:**
  - ◆ (2) 8 1/2in x 12 1/2in rectangles
  - ◆ (2) 2 3/4in x 20 1/2in strips for the bag straps
3. **From the lining fabric, cut:**
  - ◆ (2) 12 1/2in squares
4. **From the lightweight interfacing, cut:**
  - ◆ (2) 1 3/8in x 20 1/2in strips for the bag straps

## How to Make the Trick or Treat Bag

1. Use Diagram 1 as a guide to iron a 1 3/8in x 20 1/2in strip of lightweight interfacing to the wrong side of each of the (2) 2 3/4in x 20 1/2in black fabric strips. The interfacing is positioned on one long side.  
Fold and then press the strips in half lengthwise with right sides facing. Use a 1/4in seam to stitch down the long open edge. Turn the strap right side out and press again. Topstitch down both long edges using matching thread to neaten. Set aside.

**Diagram 1** ▶

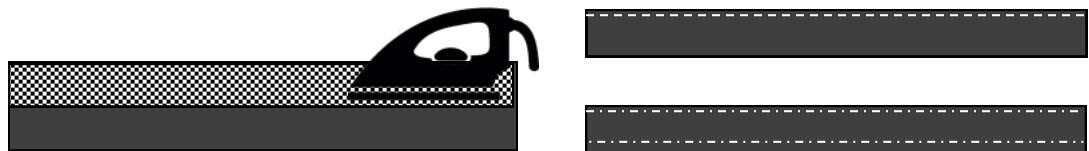

2. Sew (6) 2 1/2in squares together end to end to make a long strip. Repeat to make (2). Press the seams in each strip in opposite directions. Pin and then sew the strips together, carefully matching the seams. Press. Repeat to make (2) checked panels.
3. Pin and then sew a checked panel to the bottom of each of the (2) 8 1/2in x 12 1/2in black fabric rectangles. Press the seams open.

**Diagram 2** ▶

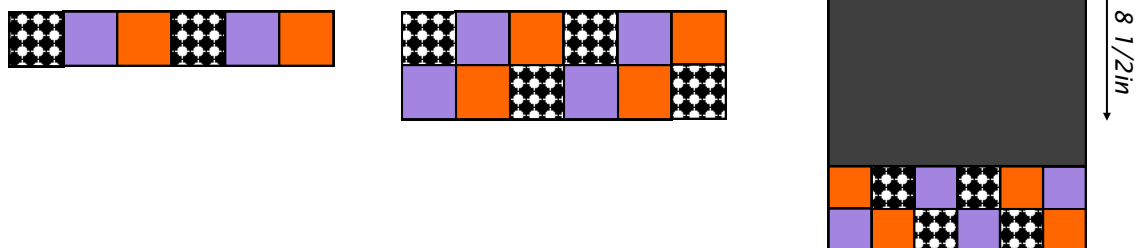



4. Trace (1) small ghost and (3) small star shapes from the template pages onto the paper side of the fusible webbing using a sharp pencil; leave approx. 1/2in between each shape. When you have finished tracing, roughly cut out the individual shapes 1/4in outside the traced lines.
5. Fuse the applique shapes to the wrong side of the fabrics you have chosen for the project following the manufacturer's instructions. Cut the shapes out carefully on the lines when cool to the touch. Remove the backing paper from the applique shapes as you go.
6. Use the Diagram 3 and the colour photograph as a guide to centre and fuse the applique ghost and stars to the front of the bag.

Stitch around the applique shapes using your favourite method. I stitched around my shapes using machine blanket stitch and matching thread. Use a light, sharp pencil to draw the features on the ghost, then backstitch using two strands of contrasting embroidery thread. Sew (2) buttons to the face for eyes. Press.

7. Measure 3in inwards from each side of the bag, front and back, and mark with pins. This is where the straps are positioned. Pin and then baste the straps, facing downward, to the right side of both bag pieces.

**Diagram 3** ▶

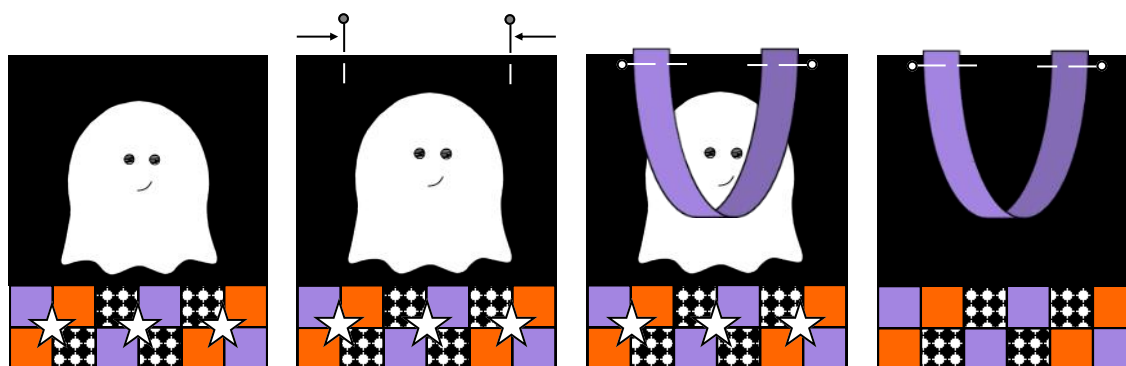

*Strap shown in purple for illustration purposes only.*

8. Pin and then sew the front and back of the bag together with right sides facing, making sure the side seams match. Leave the top edge open. Clip the corners and turn right side out. Press.
9. Pin and then sew the front and back of the bag lining together with right sides facing; leave a small opening in the side seam for turning, and the top edge unsewn. Leave the bag lining inside out.
10. Place the outer bag inside the bag lining, the right sides will be facing, and the bag straps will be sandwiched between the two layers.

Match the side seams, pin, then sew around the top edge of the bag, catching the basted ends of the straps in the seam. Backstitch the straps for strength.

**Diagram 4** ▶

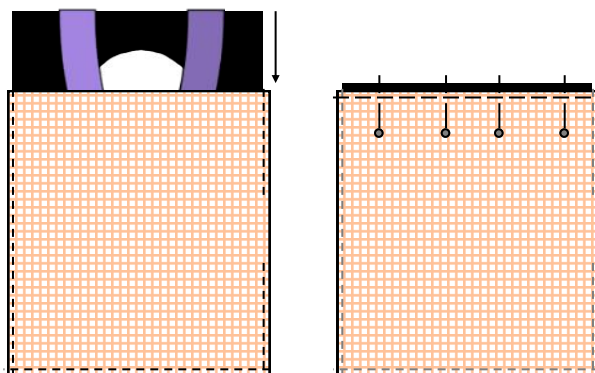

11. Turn the bag right side out through the opening in the bag lining. Hand-stitch the opening closed, then push the lining into the bag. Press, then topstitch around the top opening, sewing close to the edge, using matching thread to finish.
12. Add Deco|Foil™ to the stars for sparkle!



# GHOSTS & GHOULS

## What You Will Need for the Bunting

- ◆ (2) 8 1/2in squares of orange-on-orange print fabric
- ◆ (2) 8 1/2in squares of solid purple fabric
- ◆ (3) 8 1/2in squares of black & white print fabric
- ◆ (7) 8 1/2in squares of coordinating fabric for the back of the bunting flags
- ◆ A scrap of white-on-white print fabric for the applique
- ◆ A scrap of solid black fabric for the applique
- ◆ (1) packet of black extra wide double fold bias tape
- ◆ (2) pairs of small to medium black buttons for eyes
- ◆ Lightweight fusible webbing
- ◆ Matching thread to suit your favourite applique stitching method
- ◆ General sewing supplies
- ◆ Deco|Foil™ Hot Melt Adhesive and silver foil (optional)

## How to Make the Bunting

1. Trace the applique shapes from the template pages onto the paper side of the fusible webbing and cut out as before.

*You will need to trace (2) small ghost shapes and (2) large star shapes to make your bunting like mine.*

2. Fuse the applique shapes to the wrong side of the fabrics you have chosen for the project and cut them out when cool to the touch.
3. Use the template and the colour photograph as a guide to fuse the applique ghosts and stars to the purple and orange background blocks. The applique is placed 1 1/2in down from the top raw edge of the fabric, and centred across the width of the fabric. See Diagram 1.

Stitch around the applique shapes as before.

4. Pin and then sew the front of the bunting to the lining with right sides facing; leave the top edge open. Clip the corners and turn right side out. Press well. Topstitch, close to the edge, around (3) sides of each square using matching thread. Leave the top edge open. Press.

*Continue sewing to make as many bunting flags as you need.*

### Diagram 1 ▶

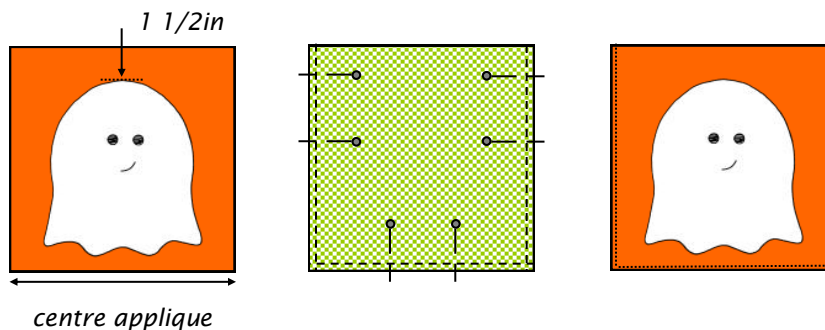

5. Lay out the flags, in order, on a flat surface. Next, take the bias tape and measure 12in in from one end. Mark with a pin. Stitch the first 12in of tape together, sewing along the open edge, using matching thread. This is the tie. See Diagram 2.

Once you have created the tie, add the first flag by opening the bias tape and slipping the raw top edge of the bunting flag inside the tape. Pin it in place.

Continue sewing along the bias tape, securing the raw edge of the bunting inside the tape.

**Diagram 2** ▶

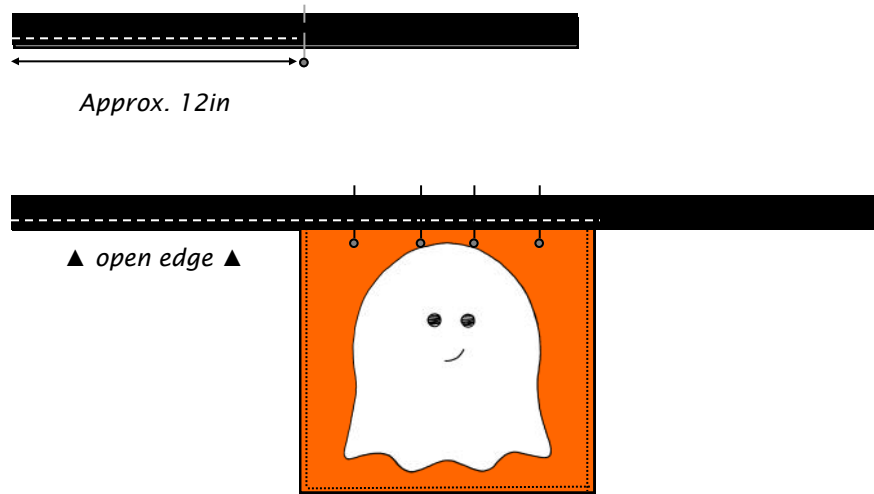

6. Continue adding the flags until you have reached the desired length of bunting you require. Leave approx. 1/2in space between each flag.

When you have secured all of the flags to the bias tape, finish the bunting by sewing a 12in tie at the end of the bias tape as before. Press gently to finish.

Keep in mind the length of the purchased bias tape when you are planning your bunting!

**Diagram 3** ▼

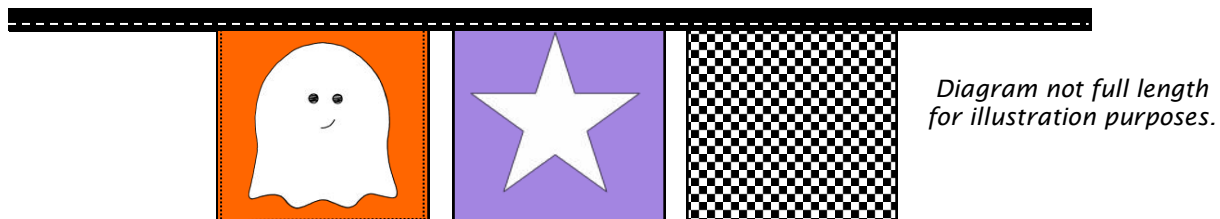

7. I've used silver Deco|Foil™ to add sparkle and bling to the stars on the bunting. Always follow the manufacturer's instructions, and make a test piece first!

**GHOSTS & GHOULS—WALL-HANGING TEMPLATES**

**FREE PDF PATTERN—NOT FOR RESALE**

© Antonie Alexander, The Red Boot Quilt Company 2016

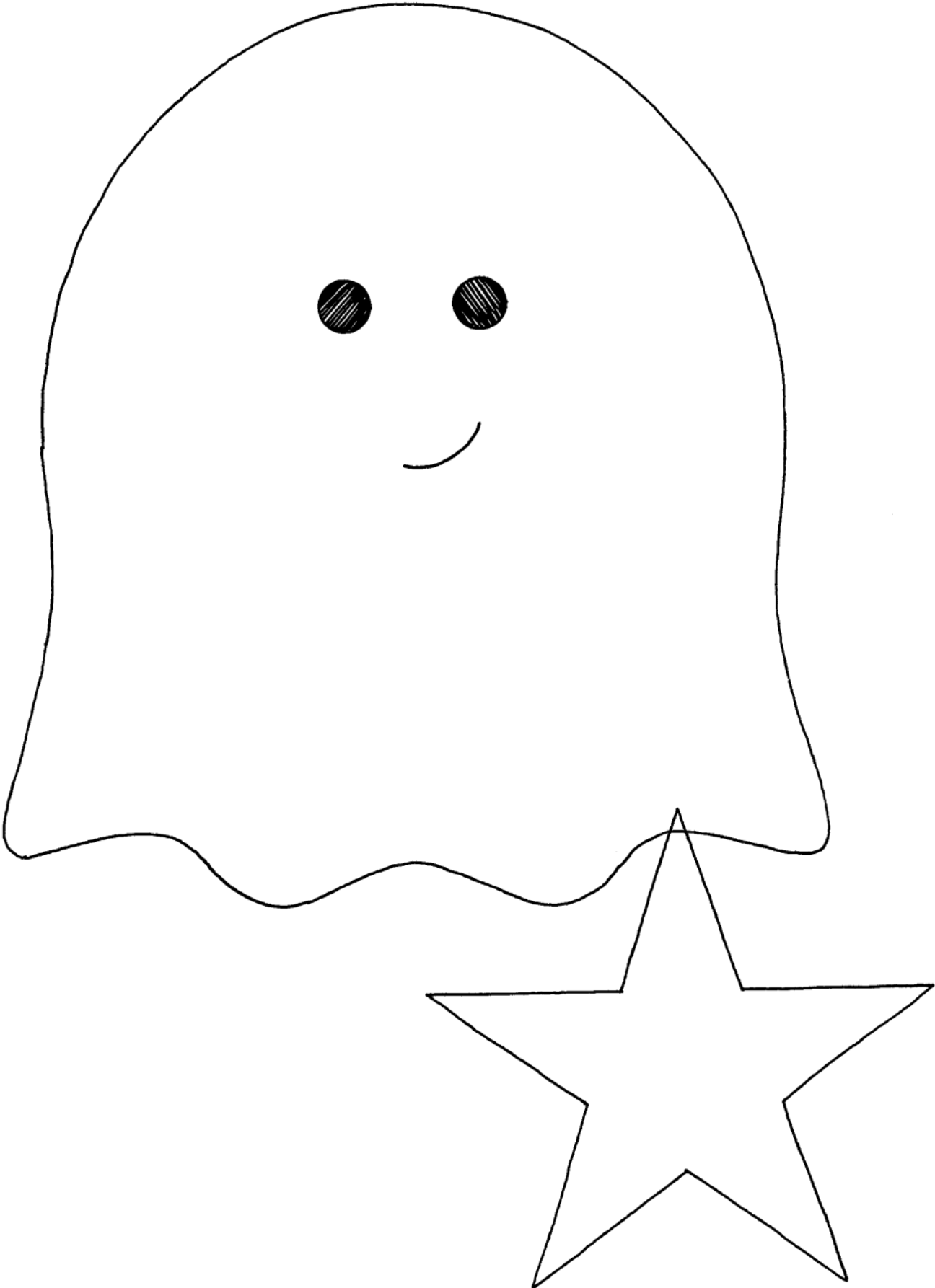

# GHOSTS & GHOULS—WALL-HANGING TEMPLATES

FREE PDF PATTERN—NOT FOR RESALE

© Antonie Alexander, The Red Boot Quilt Company 2016

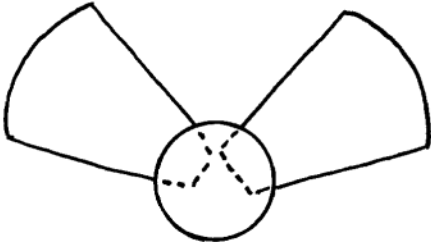
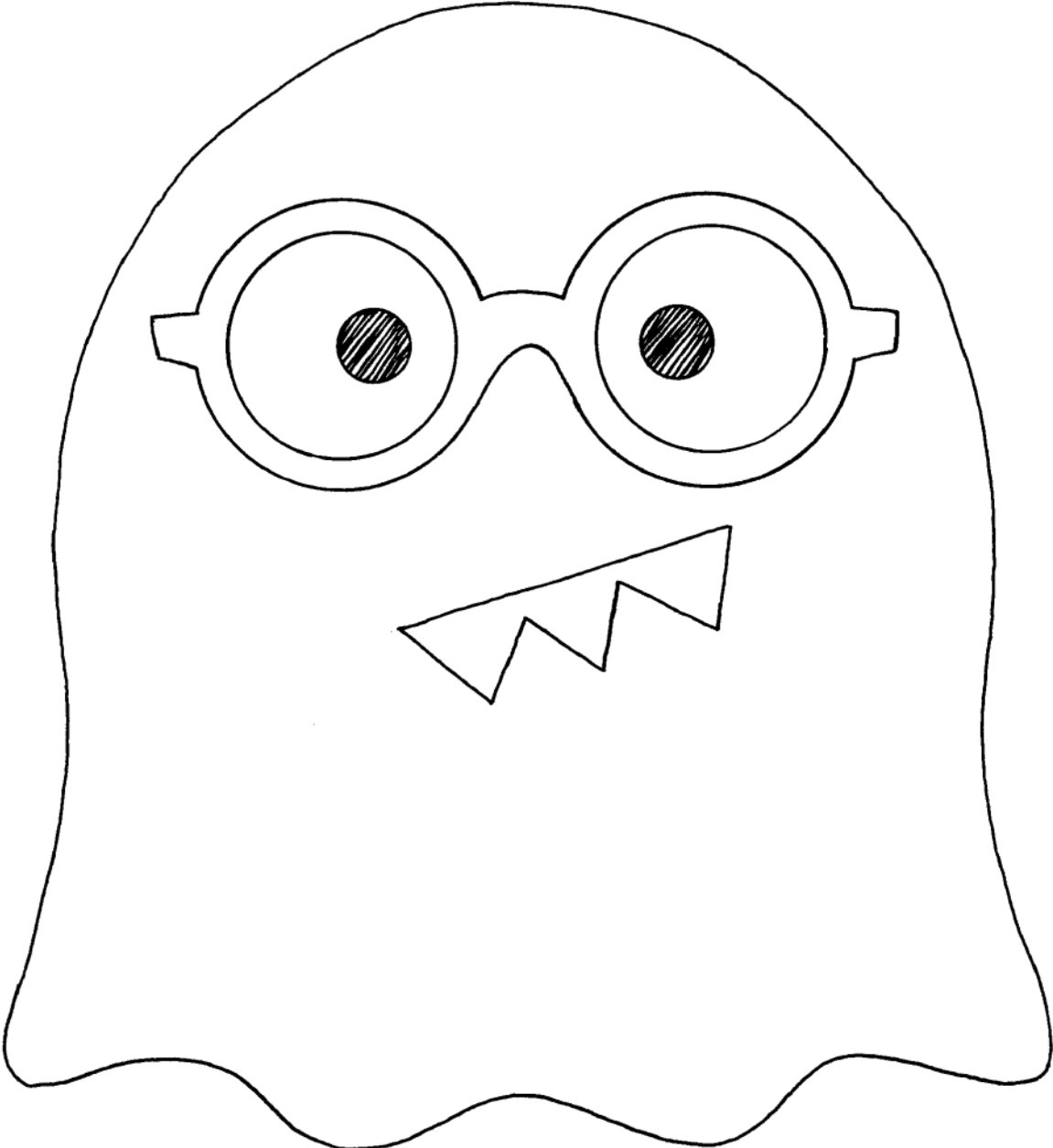

# GHOSTS & GHOULS—WALL-HANGING TEMPLATES

FREE PDF PATTERN—  
NOT FOR RESALE

© Antonie Alexander,  
The Red Boot Quilt Company  
2016

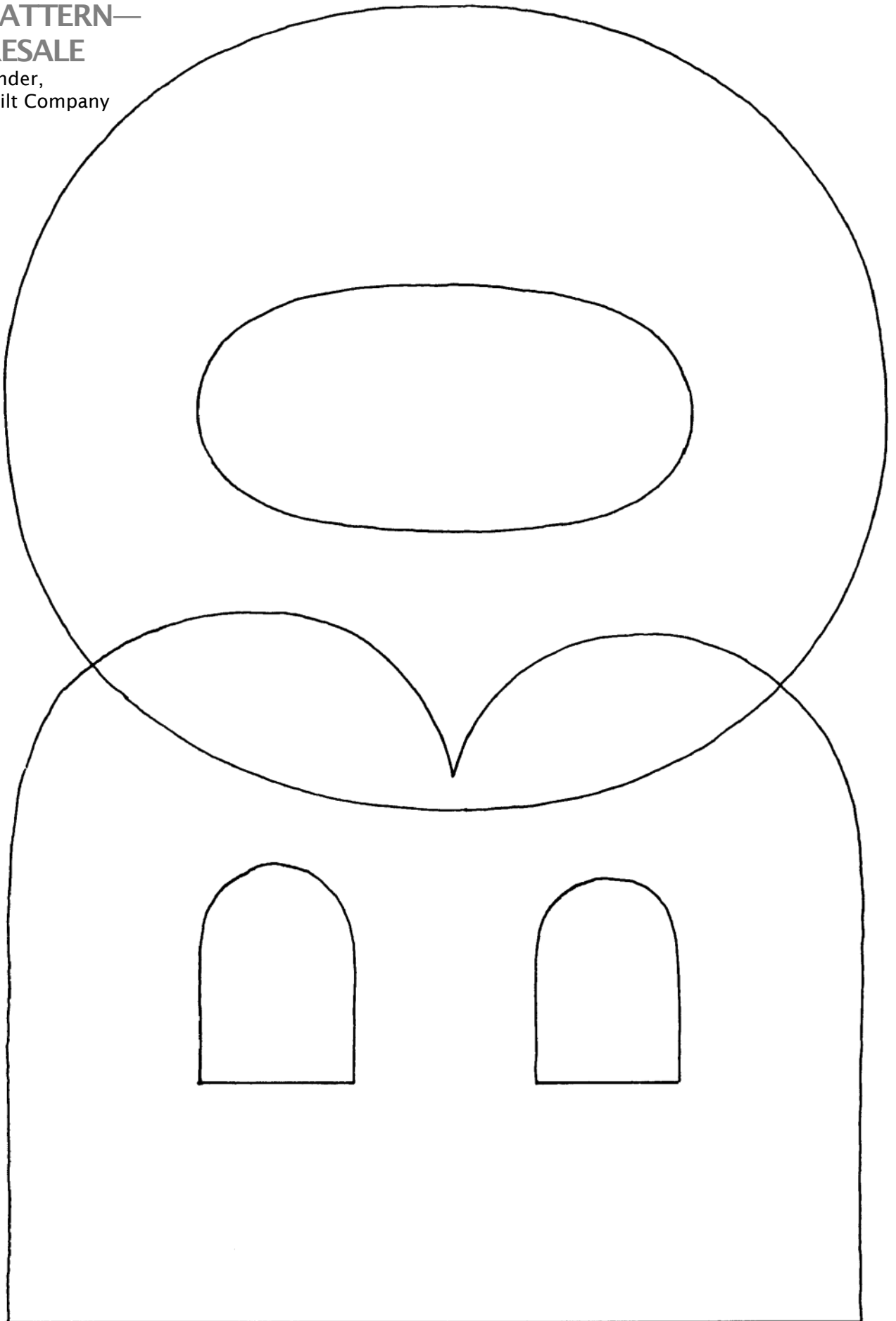

# GHOSTS & GHOULS—BAG & BUNTING TEMPLATES

FREE PDF PATTERN—NOT FOR RESALE

© Antonie Alexander, The Red Boot Quilt Company 2016

*Use small inner star for DecoFoil™*

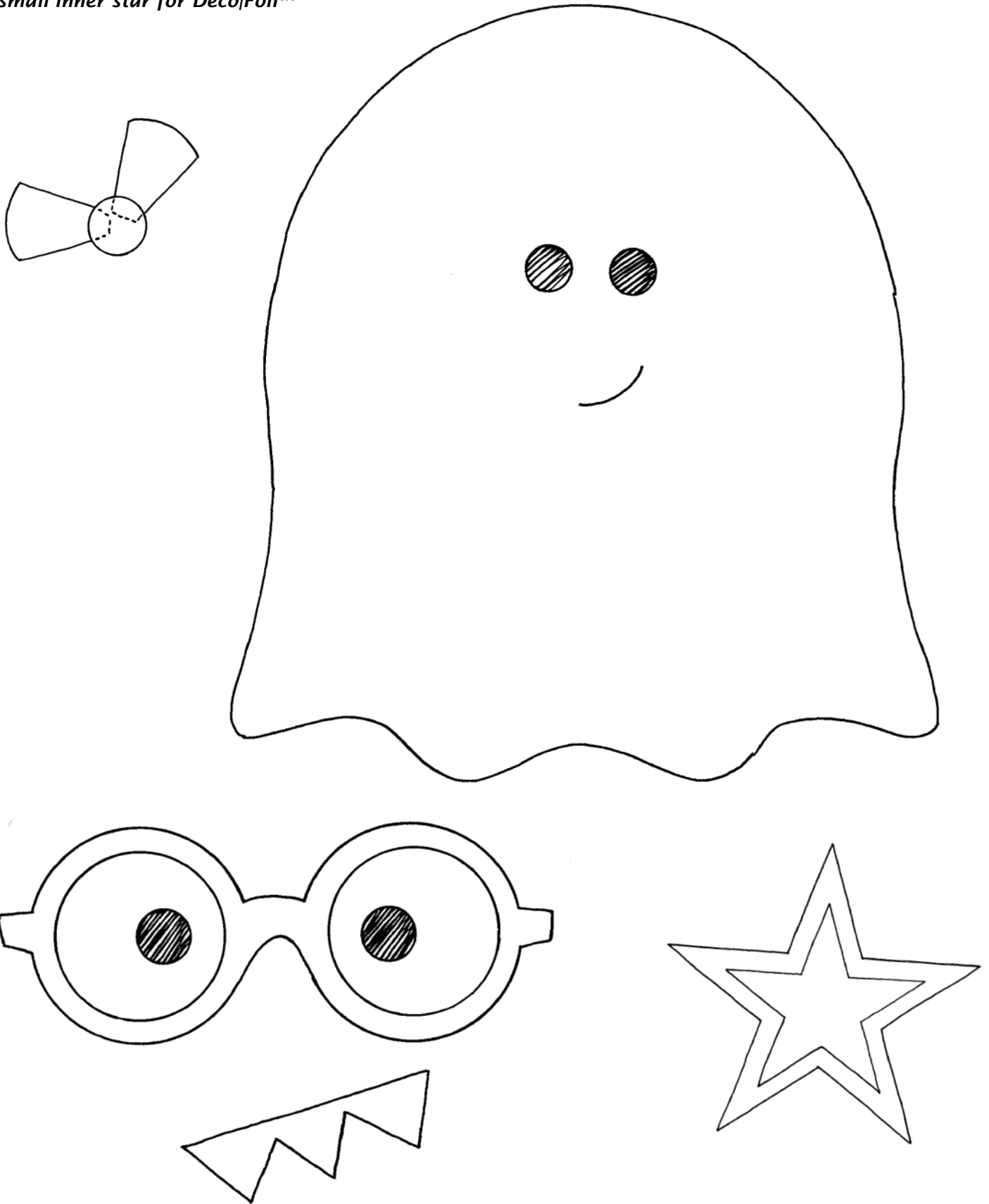

# **GHOSTS & GHOULS—BUNTING TEMPLATES**

**FREE PDF PATTERN—NOT FOR RESALE**

© Antonie Alexander, The Red Boot Quilt Company 2016

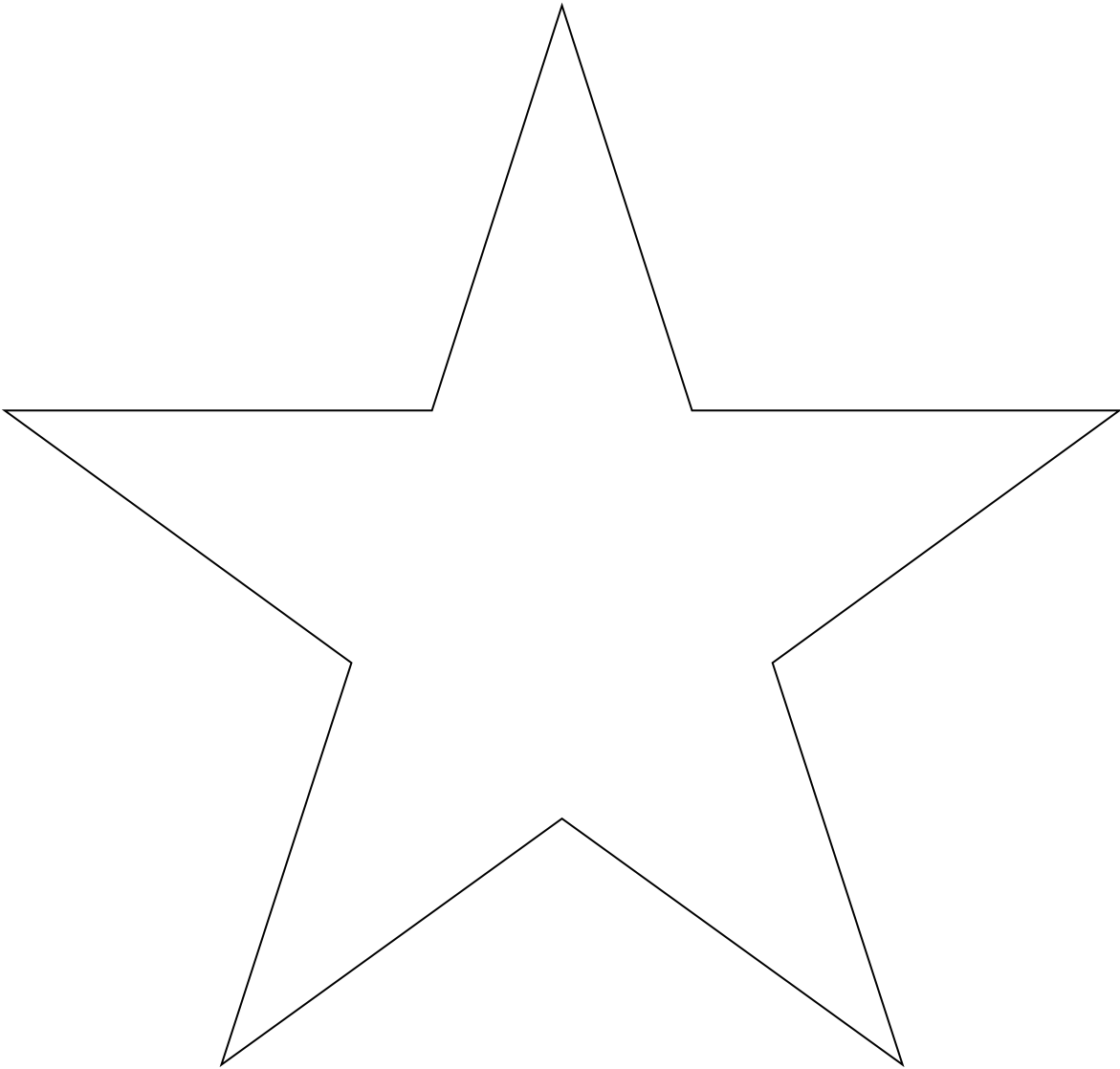

This is a free pattern provided by  
© The Red Boot Quilt Company 2017  
STRICTLY NOT FOR RESALE OR DISTRIBUTION



# GHOSTS & GHOULS—BAG & BUNTING TEMPLATES

FREE PDF PATTERN—NOT FOR RESALE

© Antonie Alexander, The Red Boot Quilt Company 2016

*Bonus Templates*

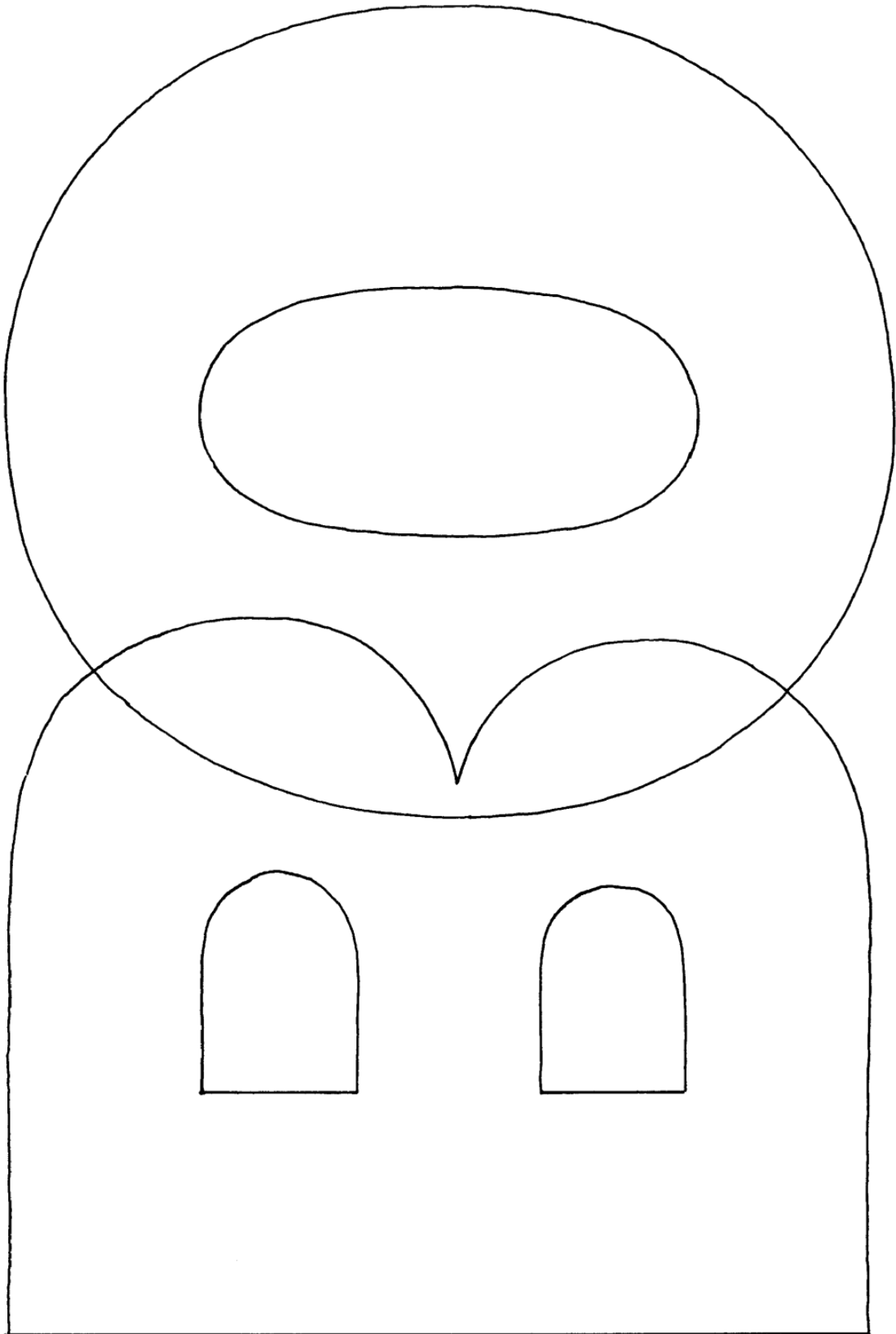

# GHOSTS & GHOULS

FREE PDF PATTERN—NOT FOR RESALE

© Antonie Alexander, The Red Boot Quilt Company 2016

## Deco|Foil™ SHAPES ONLY

*I've used Deco|Foil™ to give the stars on my wall-hanging, bag, and bunting some shimmer and shine! I've also included templates to add Deco|Foil™ to the word 'BOO'. You could also use it for the lenses in the ghosts' glasses.*

*Keep in mind when tracing the shapes for Deco|Foil™ that they don't need to be reversed for tracing.*

*DO NOT iron the Deco|Foil™ after adhering it to the projects!*

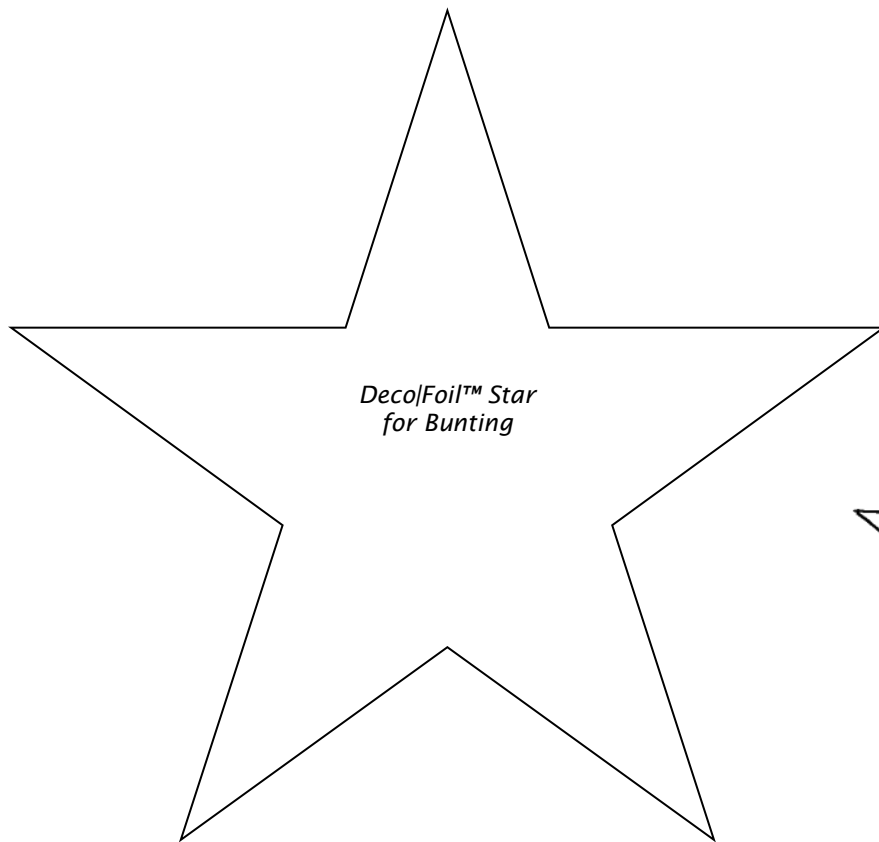

# GHOSTS & GHOULS

FREE PDF PATTERN—NOT FOR RESALE

© Antonie Alexander, The Red Boot Quilt Company 2016

Deco|Foil™ SHAPES ONLY—WALLHANGING

*Bonus Shapes*

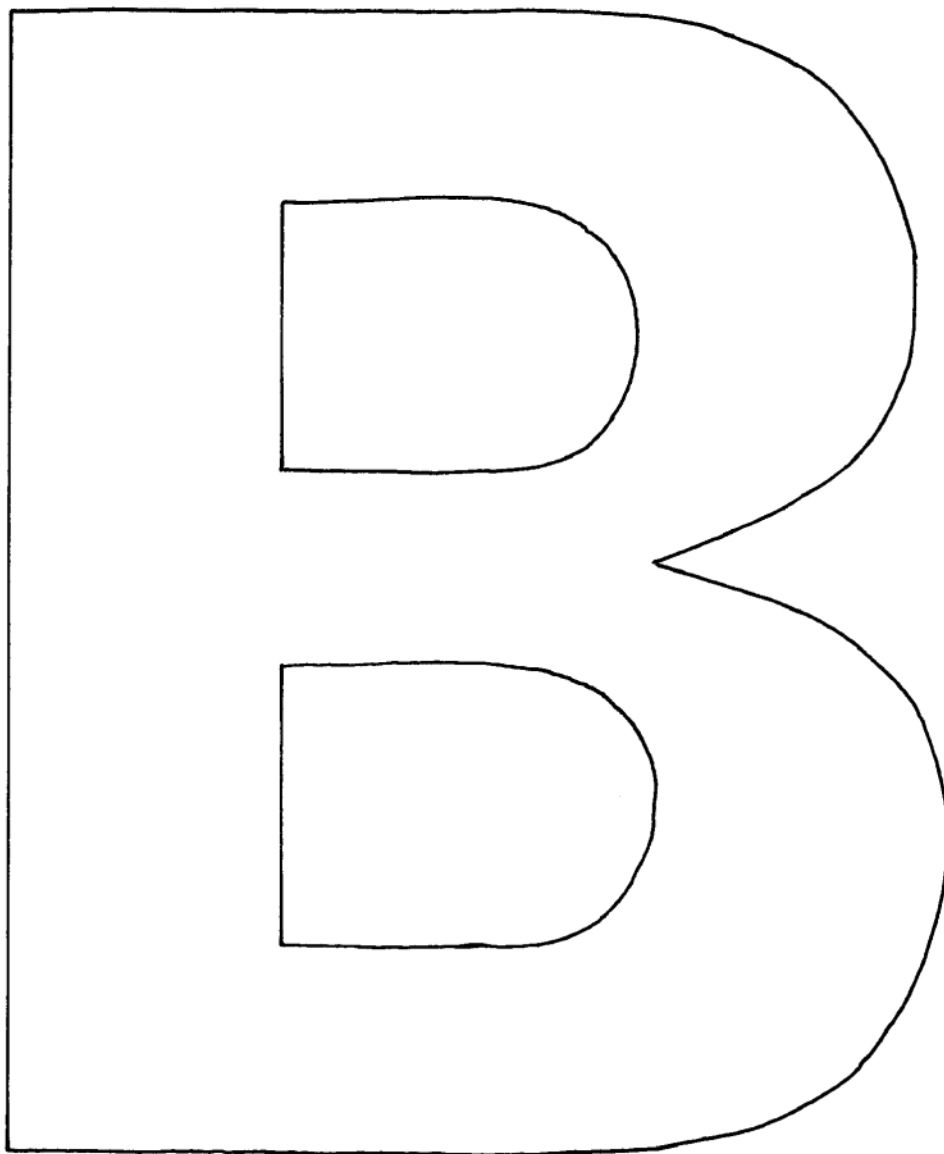

# GHOSTS & GHOULS

FREE PDF PATTERN—NOT FOR RESALE

© Antonie Alexander, The Red Boot Quilt Company 2016

Deco|Foil™ SHAPES ONLY—WALLHANGING

*Bonus Shapes*

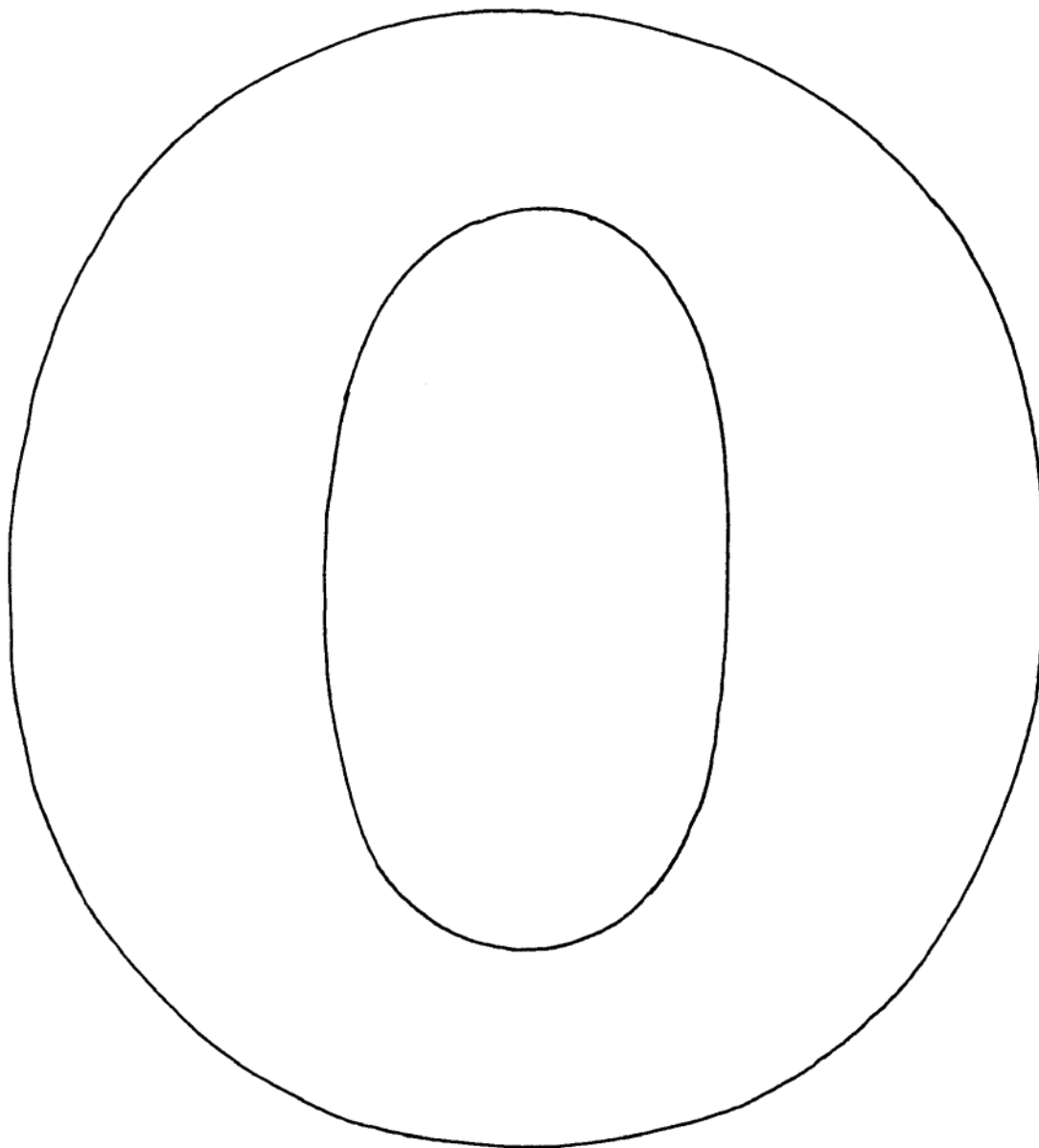

This is a free pattern provided by  
© The Red Boot Quilt Company 2017  
STRICTLY NOT FOR RESALE OR DISTRIBUTION